

major CONTROLS, INC.

LIQUID LEVEL INDICATION & CONTROL

740 Displacer Operated Liquid Level Controls

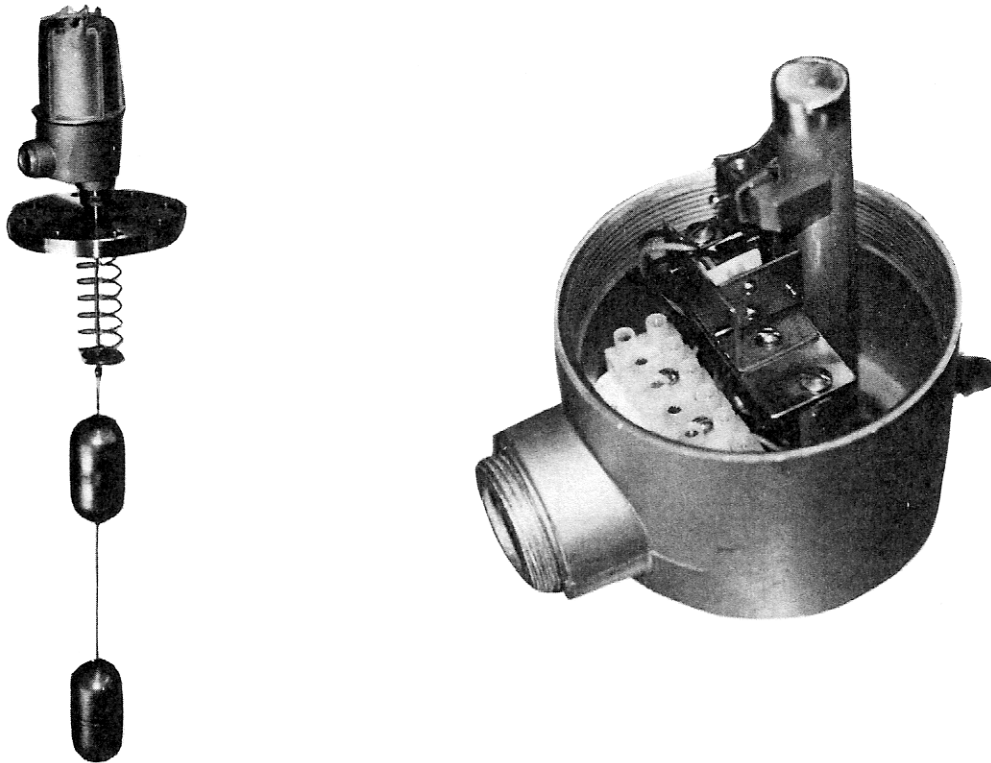

FUNCTIONS:

The Model 740 series are displacer operated units designed for use within the petroleum, power and natural gas industries. The operating principle utilizes a positive magnetic coupling to assure a reliable switch actuation for level alarm or control functions. This series is designed for internal mounting through the top of the process vessel. The use of displacers as a sensing means allows for a narrow or wide switching differential, field adjustable switching points, high pressure applications and multiple switching points by means of dual switching mechanisms.

These units are designed to provide high pressure capabilities with low specific gravity ratings. The modular concept allows for versatility of selecting the most economical combination while "Custom Engineering" the control or a particular application.

FEATURES:

- * Vessel Materials - ASTM & ANSI Grades
- * Switch Mechanism - 300 Series Stainless Steel
- * Special Construction/Function: Special Alloys, Mounting Dimensions & Process Connections
Special Actuation Points, Interface Detection, NACE, Special High Pressure & Temperature Units. Consult Factory for these Special design and Functions.

Construction Versatility:

Standard construction includes a process connection of carbon steel with a choice of NPT or flanged tank connections.

Various models are available to meet a variety of applications. A wide selection of connection & trim materials, switch mechanisms and enclosures can also be provided.

Displacer Control Operating Principle:

As the liquid level rises, the buoyancy force produced by the displacer causes the range spring to seek a new balance. This action moves the attached magnetic attraction sleeve into the field magnet located in the switch housing. As this magnet swings toward the enclosing tube, it causes the microswitch to actuate. As the liquid level falls, the magnetic attraction sleeve moves out of the magnetic field and the bias spring pulls the magnet away from the enclosing tube which deactuates the microswitch.

Displacer Advantages:

1. Ability to withstand higher pressure than a float, since displacers can be solid or constructed with a much heavier wall.
2. Allows wide switching differentials.
3. Allows switch point to be adjusted by moving the displacer up or down.

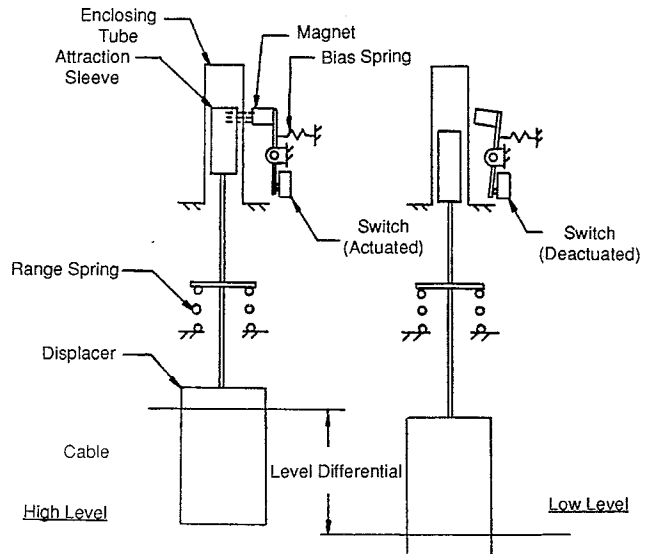

major CONTROLS, INC.

LIQUID LEVEL INDICATION & CONTROL

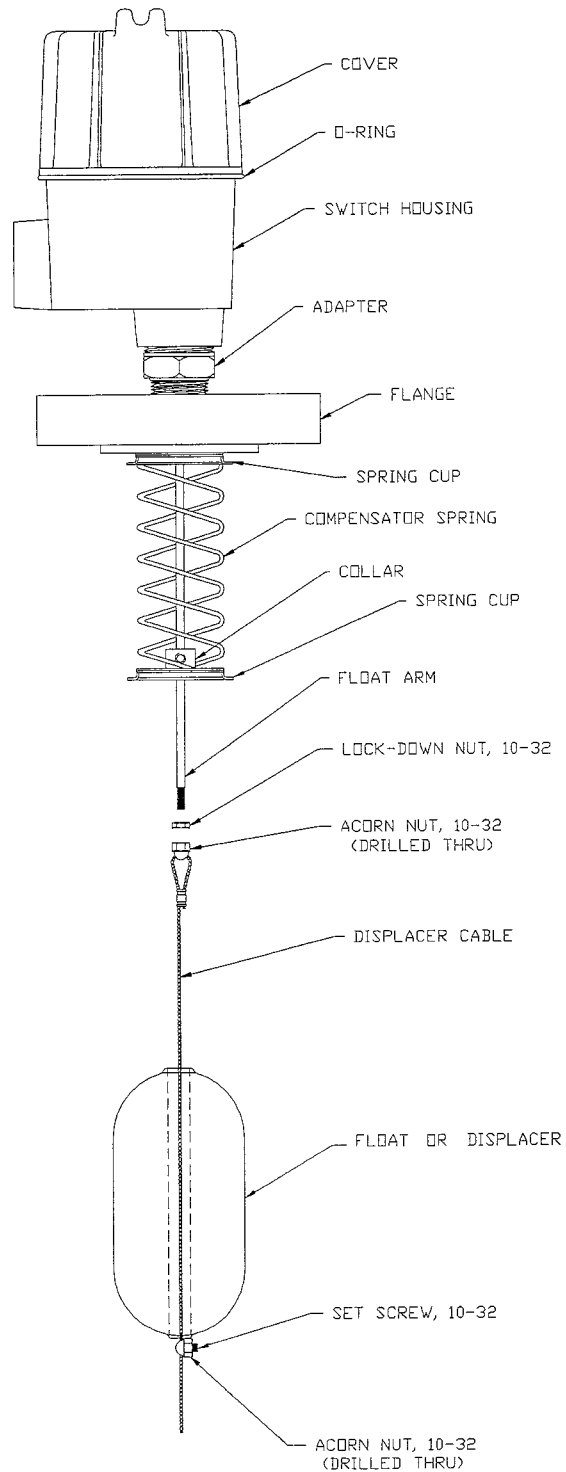

MAJOR MODEL 740 INSTALLATION & OPERATION INSTRUCTIONS

OPERATION

The stainless steel float (displacer) heavier than the liquid is suspended by a spring. When liquid rises around the displacer, a buoyancy force is produced, which causes the effective weight of the displacer to change. This causes the spring to retract slightly to a new equilibrium position. When the spring retracts, the attraction sleeve also moves upward into the field of the external magnet. The magnet moves forward toward the attraction sleeve which actuates the micro switch. If the 740 is a dual switch unit the second switch will actuate when the second float (displacer) causes the spring to retract again causing the second magnet to move forward toward the attraction sleeve.

INSTALLATION

The float(s) on the cable have been preset to your requested switch point(s). The float cable assembly must be attached to the float arm. Attach the float cable assembly to the float arm with the acorn nut that suspends the float assembly (*see attached diagram*). When the acorn nut has been threaded onto the float arm as far as possible, lock the acorn nut in place with the 10-32 lock down nut. The 740 control and float assembly is now ready to be installed in the vessel.

Should you need to change the switch actuation point, remove the 740 control and float assembly from the tank, loosen the set screw in the float support acorn nut and slide the stainless steel cable through the support acorn nut to the correct position for your new actuation point. Tighten the set screw in the float support acorn nut tightly. Reinstall the 740 control and float assembly into vessel.

WIRING INSTRUCTION FOR THE 740 SERIES WITH TANDEM SWITCHES

With float in down position (no fluid) the wire terminals are as follows.

Top set point

Terminal #1 common

Terminal #2 normally closed

Terminal #3 normally opened

Bottom set point

Terminal #4 common

Terminal #5 normally closed

Terminal #6 normally open

WIRING INSTRUCTION FOR THE 740 SERIES WITH SINGLE SWITCH

With float in down position (no fluid) the wire terminals are as follows.

Terminal #1 common

Terminal #2 normally closed

Terminal #3 normally opened

major CONTROLS, INC.

LIQUID LEVEL INDICATION & CONTROL

740 Displacer Operated Liquid Level Control

Pressure Rating / Specific Gravity:

Code	Switch Function	Pressure Rating (PSIG)								Minimum S.G.*
		NPT		Flanged						
		100 F	450 F	150#		300#		600#		
		100 F	450 F	100 F	450 F	100 F	450 F	100 F	450 F	
1	Narrow Differential	1000	750	285	95	740	615	1480	1235	.60
2	Wide Differential	1000	750	285	95	740	615	1480	1235	.55

* One Switch Only

Switch Outputs:

Code		Dry Contact	Ambient Temp. Limit (F)	Electrical Rating
SPDT	DPDT			
SF	SG	Standard	-40 to 160	5A @ 115 VAC
SR	SS	High Temperature	-40 to 450	5A @ 125 VAC
SK	SL	Gold Contact	-40 to 160	1A @ 125 VAC
ST	SU	Hermetically Sealed	-40 to 160	1A @ 125 VAC

Process Connections Size & Type:

Process Connection Orientation (See back page)	Connection Size & Type Designator										
	NPT Size		Flanged Size & Rating								
			2 1/2"			3"			4"		
	2 1/2"	3"	150#	300#	600#	150#	300#	600#	150#	300#	600#
TOP	BA	BB	BC	BD	BE	BF	BG	BH	BI	BJ	BK

Materials Available:

Material Code	Materials of Construction
A	ASTM A 105/A 106: Carbon Steel Connection; All 304 SST Trim,
B	ASTM A 105/A 106: Carbon Steel Connection; All 316 SST Trim
C	ASTM A 234 Type 304 SST Connection; All 316 SST Trim
D	ASTM A 234 Type 316 SST Connection; All 316 SST Trim
X	Specify Required Material

Switch Enclosure:

Housing Designator	Area Classification	Material
1	General Purpose - NEMA 4	Aluminum
2	E.P. Class I GRP C&D - NEMA 7	Aluminum

Options:

Code	Available Options	Code	Available Options
A	Alloy Construction (State Material)	K	Karbate Displacers
C	Epoxy Coated Unit	N	NACE Construction to MR - 01 - 75
D	Dual Stage Control	T	Teflon Displacers
E	Guide Cage - 12" - 48"	S	Stainless Steel Tag
F	Stilling Well - 12" - 48"	X	Specify Any Additional Options
G	316 SST Enclosing Tube		Required
H	Alloy Cable - Monel, Hast - C, Alloy 20		
I	Interface Detection		

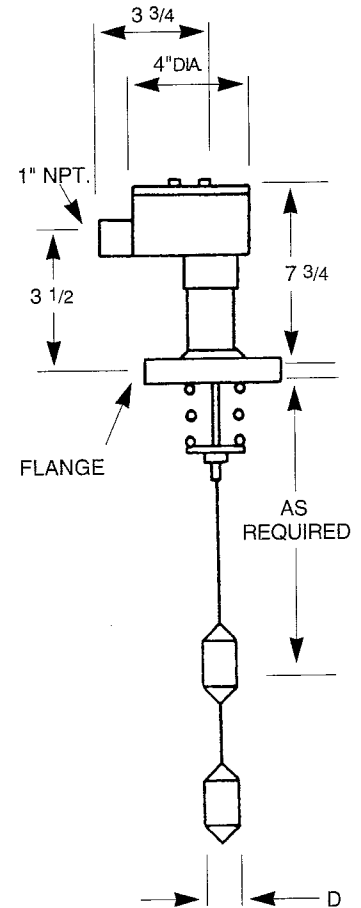
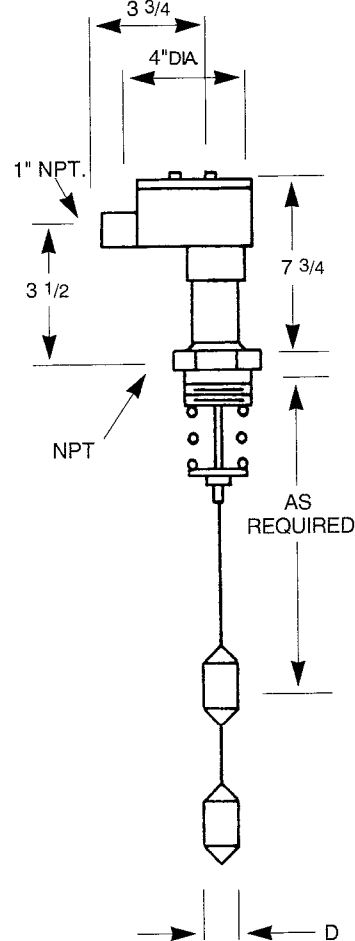
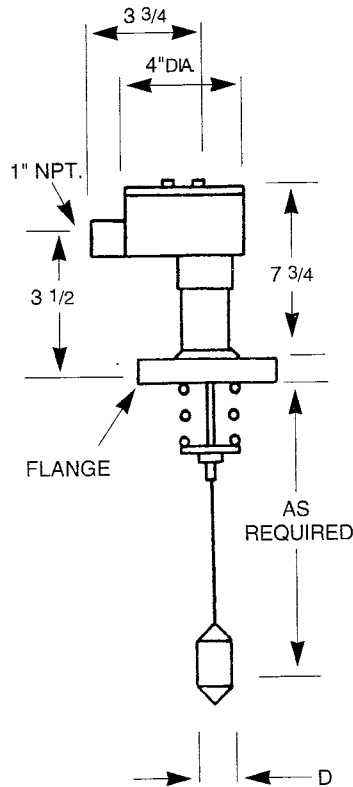
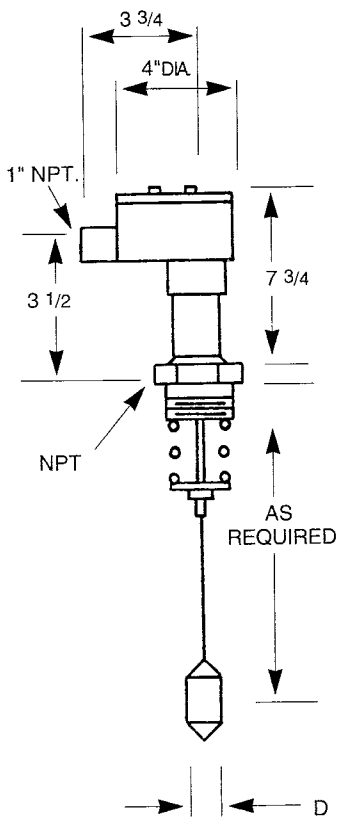
Narrow Differential**Wide Differential****NPT****Flanged****NPT****Flanged****Displacer Dimensions:**

Material	Diameter (D)		Length	
	IN	MM	IN	MM
Porcelain	2 9/16	65	7 1/2	190
Stainless Steel	2 1/2	63	7 1/2	190
Karbate	2 1/2	63	9	228

1. Porcelain displacers cannot be used on nonvented water systems over 200 F (93 C).
2. Maximum liquid specific gravity on wide differential controls is 1.2 S.G.
3. Temperature affect will increase actuation level approximately 3/4" per 100 F temperature rise.